

REVISIONS				
ZONE	REV.	DESCRIPTION	DATE	APPROVED
	A	INITIAL RELEASE	6/21/2021	JAKE JANOSO

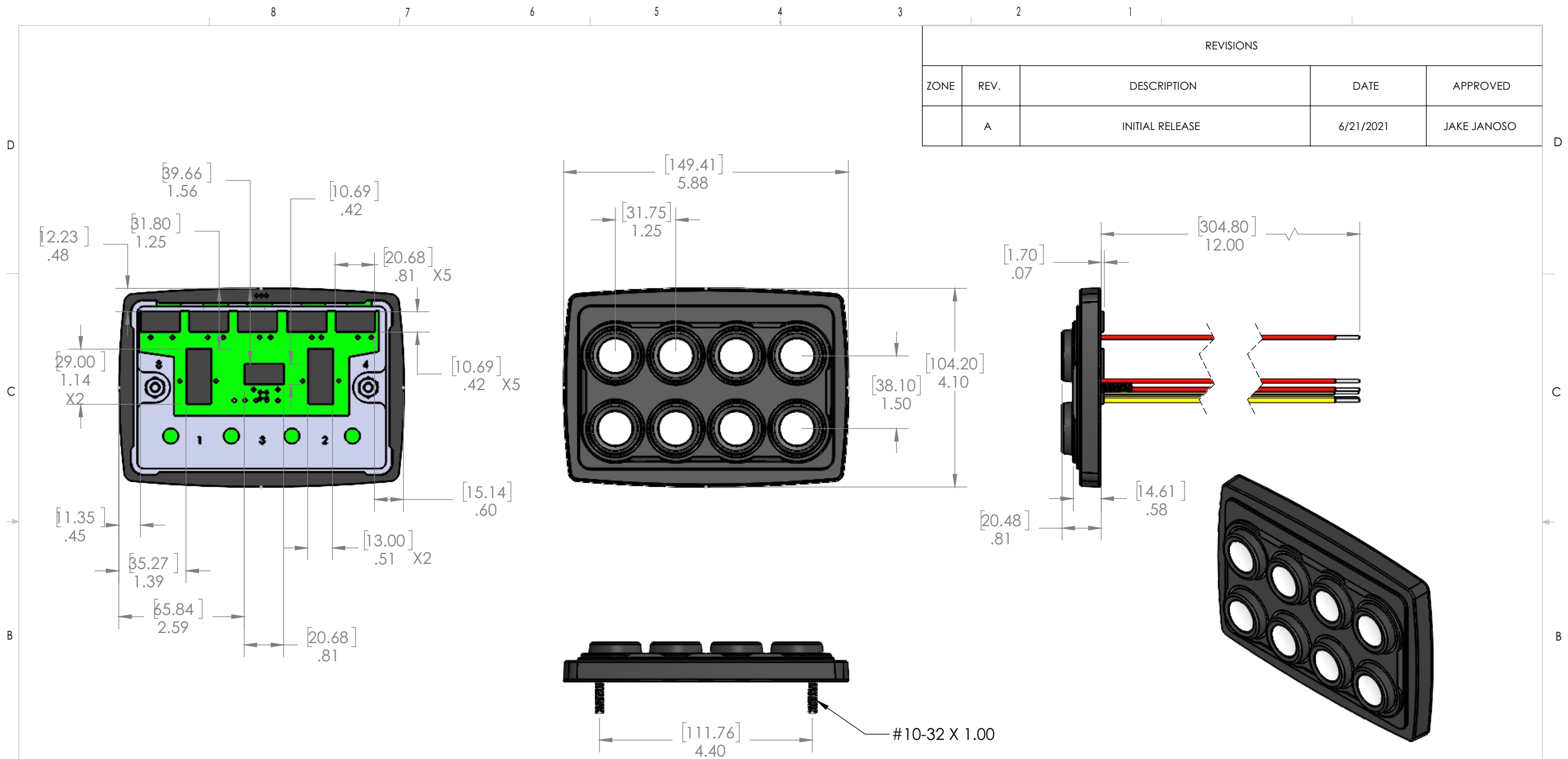

REVISION(S) PER ECN #:	UNLESS OTHERWISE SPECIFIED:	NAME	DATE	Googolplex Electric Co.
ECN DESCRIPTION:	DIMENSIONS ARE IN INCHES [MM] TOLERANCES: FRACTIONAL ± ANGULAR: MACH ± BEND ± TWO PLACE DECIMAL ±0.01 THREE PLACE DECIMAL ±0.005	DRAWN JAJ	6/21	
<b>PROPRIETARY AND CONFIDENTIAL</b> THE INFORMATION CONTAINED IN THIS DRAWING IS THE SOLE PROPERTY OF GEC. ANY REPRODUCTION IN PART OR AS A WHOLE WITHOUT THE WRITTEN PERMISSION OF GEC IS PROHIBITED.	INTERPRET GEOMETRIC TOLERANCING PER:	CHECKED		SIZE
	MATERIAL	ENG APPR.		DWG. NO.
	FINISH	MFG APPR.		REV
DO NOT SCALE DRAWING	COMMENTS:	Q.A.		<b>B</b>
				<b>PKR2400</b>
				<b>A</b>
				SCALE: 1:2 WEIGHT: 455g SHEET 1 OF 1

REVISIONS			
REV.	DESCRIPTION	DATE	APPROVED
A	INITIAL RELEASE	2/8/2018	JUSTIN HALL
B	ADDED TEMPLATE NOTE	7/28/2020	JAKE JANOSO

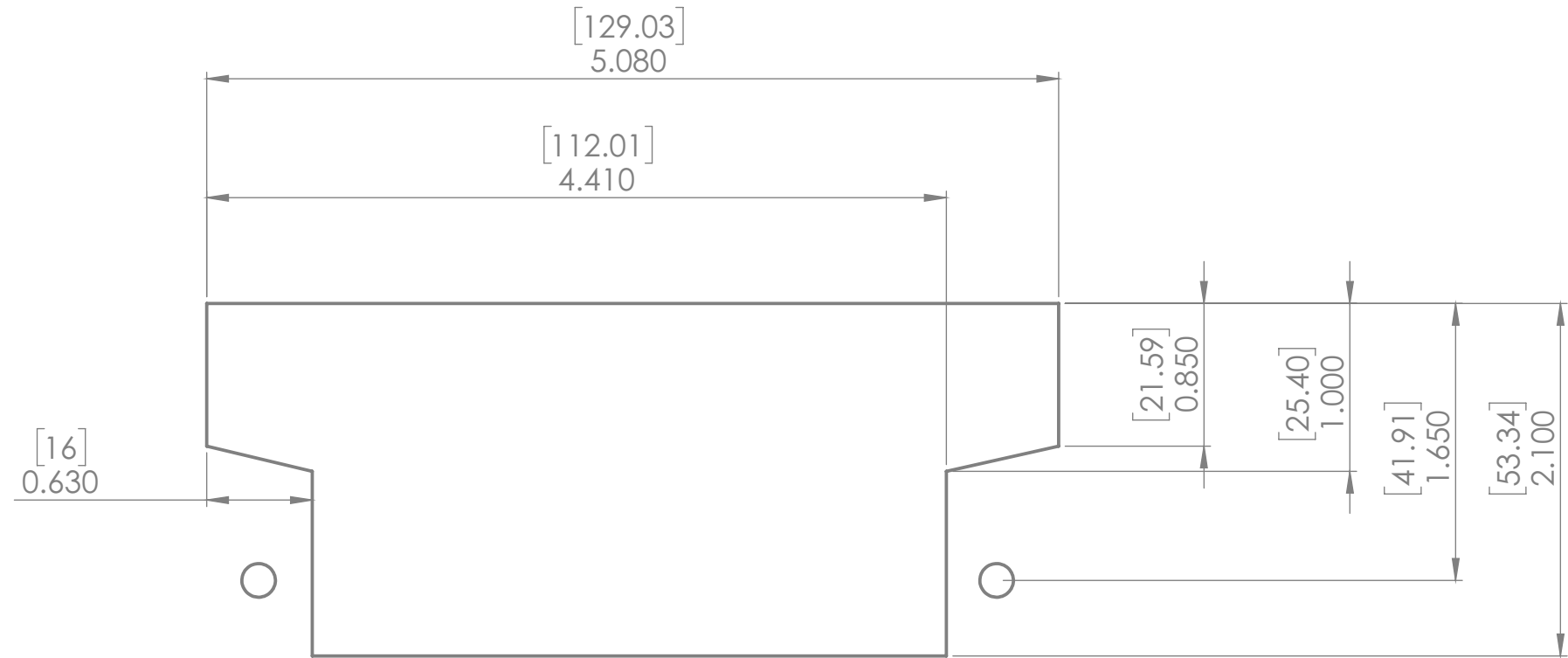

UNLESS OTHERWISE SPECIFIED:	NAME	DATE
DIMENSIONS ARE IN INCHES	DRAWN	JRH
TOLERANCES:	CHECKED	
FRACTIONAL ±	ENG APPR.	
ANGULAR: MACH ±1 BEND ±1	MFG APPR.	
TWO PLACE DECIMAL ±.01	Q.A.	
THREE PLACE DECIMAL ±.005	COMMENTS:	
INTERPRET GEOMETRIC TOLERANCING PER:		
MATERIAL		
FINISH		
DO NOT SCALE DRAWING		

Googolplex Electric Co.		
TITLE:		
<b>PKR2400 CUTOUT</b>		
SIZE	DWG. NO.	REV
<b>A</b>	<b>PKR2400</b>	<b>B</b>
SCALE: 1:1	WEIGHT: 455g	SHEET 1 OF 2

**PROPRIETARY AND CONFIDENTIAL**  
 THE INFORMATION CONTAINED IN THIS DRAWING IS THE SOLE PROPERTY OF GEC. ANY REPRODUCTION IN PART OR AS A WHOLE WITHOUT THE WRITTEN PERMISSION OF GEC IS PROHIBITED.



REVISIONS				
ZONE	REV.	DESCRIPTION	DATE	APPROVED
-	-	See Sheet1	-	-

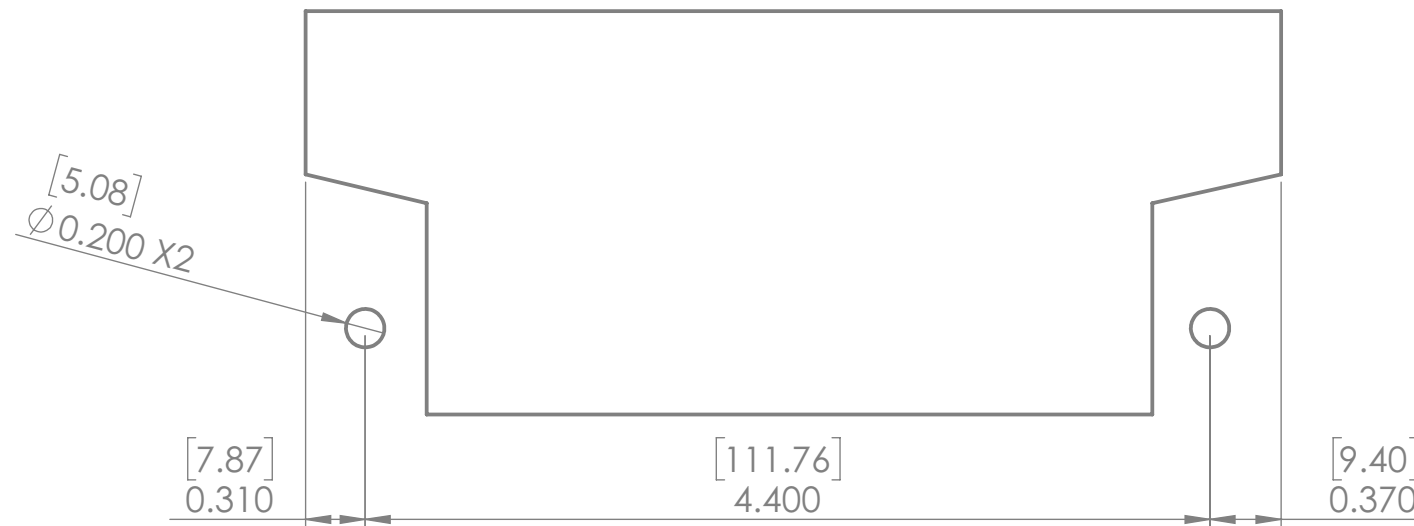

**TEMPLATE NOTE:** ALL DIMENSIONS ARE 1:1  
PLEASE VERIFY SCALING PRIOR TO DRILLING



**PROPRIETARY AND CONFIDENTIAL**  
THE INFORMATION CONTAINED IN THIS DRAWING IS THE SOLE PROPERTY OF GEC. ANY REPRODUCTION IN PART OR AS A WHOLE WITHOUT THE WRITTEN PERMISSION OF GEC IS PROHIBITED.

UNLESS OTHERWISE SPECIFIED:	NAME	DATE
DIMENSIONS ARE IN INCHES	DRAWN	JRH
TOLERANCES:	CHECKED	5/19
FRACTIONAL ±	ENG APPR.	
ANGULAR: MACH ±1 BEND ±1	MFG APPR.	
TWO PLACE DECIMAL ±.01	Q.A.	
THREE PLACE DECIMAL ±.005	COMMENTS:	
INTERPRET GEOMETRIC TOLERANCING PER:		
MATERIAL		
FINISH		
DO NOT SCALE DRAWING		

Googolplex Electric Co.

TITLE:

**PKR2400 CUTOUT**

SIZE	DWG. NO.	REV
<b>A</b>	<b>PKR2400</b>	<b>B</b>

SCALE: 1:1 WEIGHT: 455g SHEET 2 OF 2

5

4

3

2

1

## PKR2400 DIMENSIONS

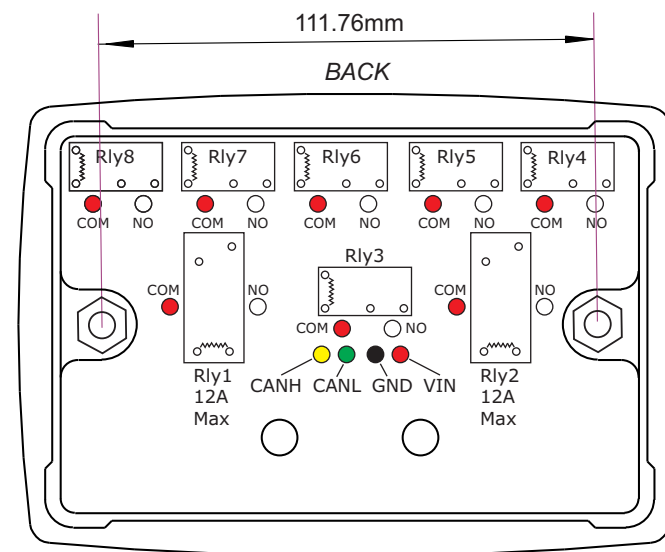
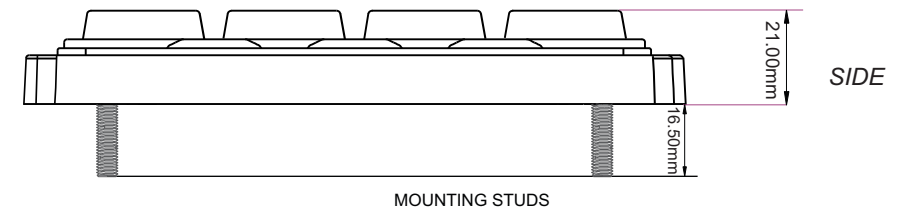
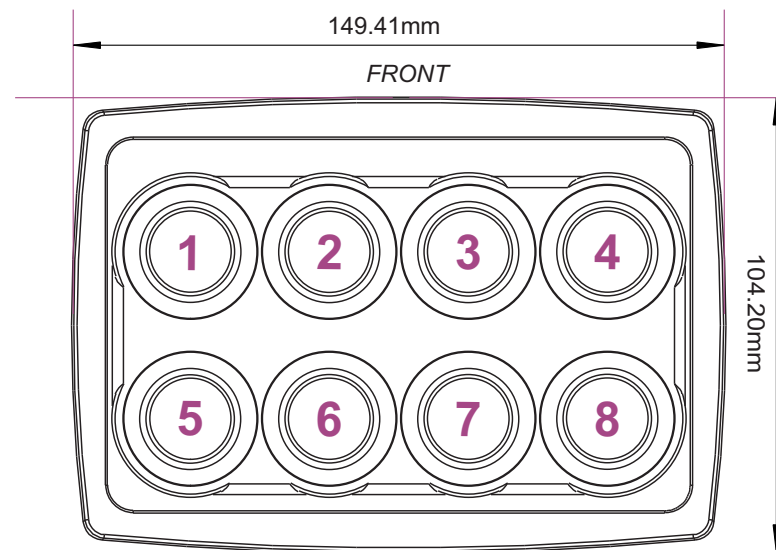

\*Diagrams are NOT to Scale

### MOUNT ON A FLAT SURFACE ONLY

Part Number:	GEC-PKR2400
Weight:	455g
Nut Size*:	10-32 UNF S/S
Washer Sizes:	M5 Spring Washer S/S, M5 Flat Washer S/S
Torque Mounting Nuts:	7 +/- 1 in. lbs

\* DO NOT USE NYLOC NUTS

 Gogolplex Electric Co.